

DESCRIPTION

The HBUC series broadband balanced upconverters cover a wide range of waveguide bands from 18 -110 GHz. They utilize a low loss structure mated to a matched pair of GaAs Schottky beam lead diodes for minimum conversion loss and maximum bandwidth. Superior LO noise suppression and LO -RF isolation values are design features.

Upconverters are used to create a millimeter wave signal by combining a lower IF frequency with a higher MMW LO frequency. Dual signals, or double sidebands are produced in this way: $LO \pm IF$ (DSB). Optional filters are offered to suppress the unwanted sideband and produce a single sideband (SSB) upconverter. Biased versions are available for lower LO drive levels.



Applications

- Frequency Converters
- Signal Processing
- EW / ELINT Systems
- Frequency Measurement
- Modulation Translators

Features

- High IF Bands
- Moderate LO Drive Level
- Compact Design
- Low Conversion Loss
- Optional Filters

Specifications @ 35°C T_{CASE}, Specifications subject to change w/o notice.

Model Number	Frequency* (GHz)	Waveguide Band	RF Output Power** (typical) P _{LO} @ +13 dBm F _{IF} @ 2 GHz P _{IF} @ +10 dBm
HBUC42	18.0 – 26.5	WR – 42	+4.0 dBm
HBUC28	26.5 – 40.0	WR – 28	+4.0 dBm
HBUC22	33.0 – 50.0	WR – 22	+4.0 dBm
HBUC19	40.0 – 60.0	WR – 19	+1.5 dBm
HBUC15	50.0 – 75.0	WR – 15	+1.0 dBm
HBUC12	60.0 – 90.0	WR – 12	+1.0 dB
HBUC10	75.0 – 110.0	WR – 10	0 dB

*Please specify desired RF, LO and IF frequency ranges when inquiring about balanced mixers.

**Saturated output power

General Specifications

LO to RF Isolation	20dB (typical)
VSWR (RF, LO, IF)	2.0:1 (typical)
LO Drive Level (P _{LO}) unbiased	+13 dBm nominal
LO Drive Level, biased	+10 nominal
P _{1dB} compression point	+0 dBm (typical) w/ +13 P _{LO}
P _{IF} Maximum	+20 dBm CW, + 24 dBm pulsed
Diode Bias (option)	+6.0 VDC @ 10 mA
Operating Temperature	-20 to +60°C

Balanced Upconverter Outlines

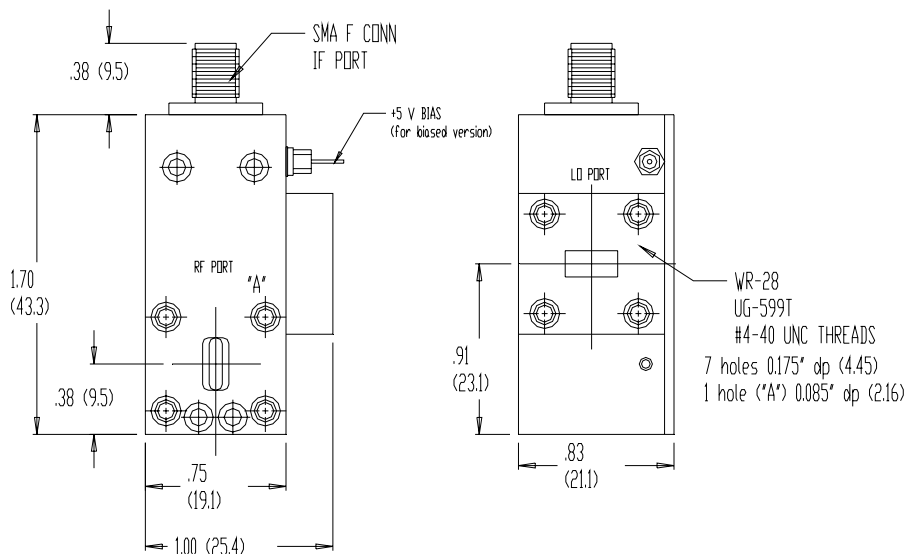

Ka-Band Balanced Upconverter

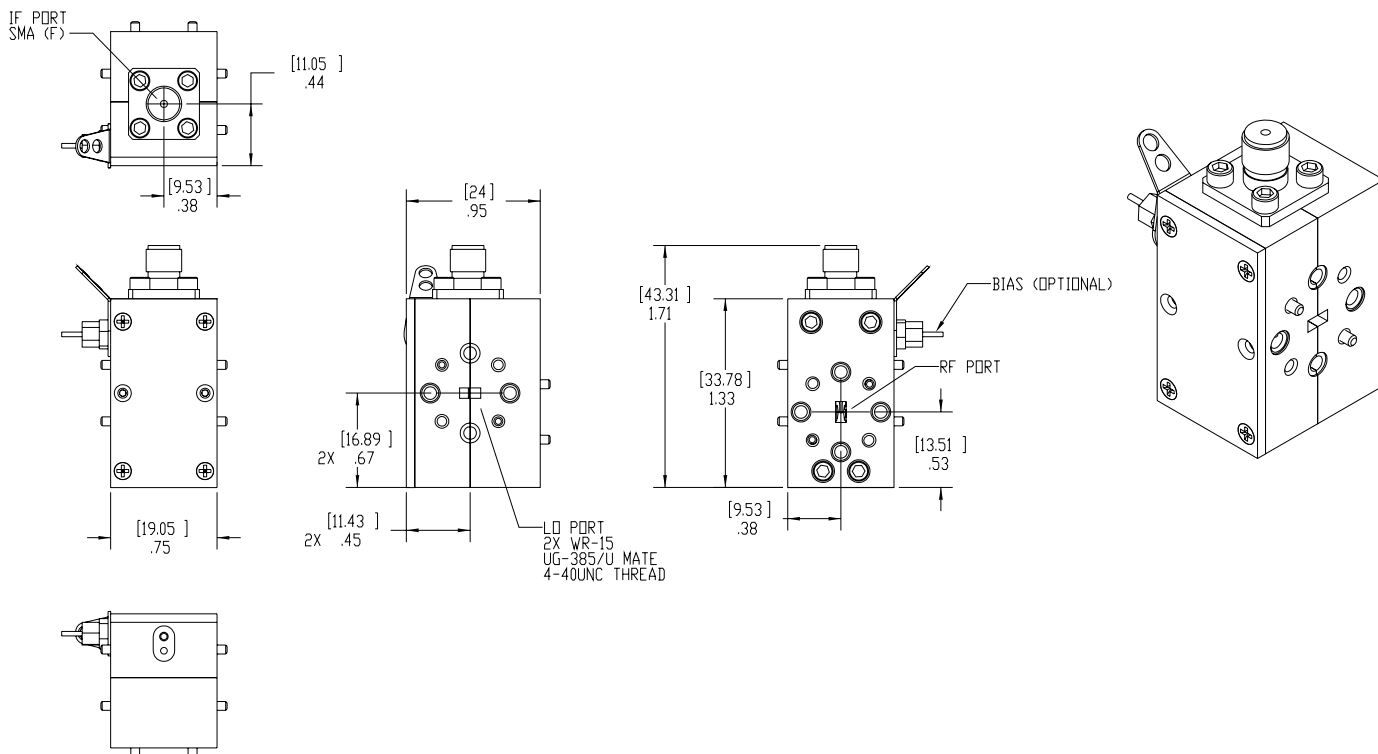

V-Band Balanced Upconverter

Balanced Upconverter Outlines

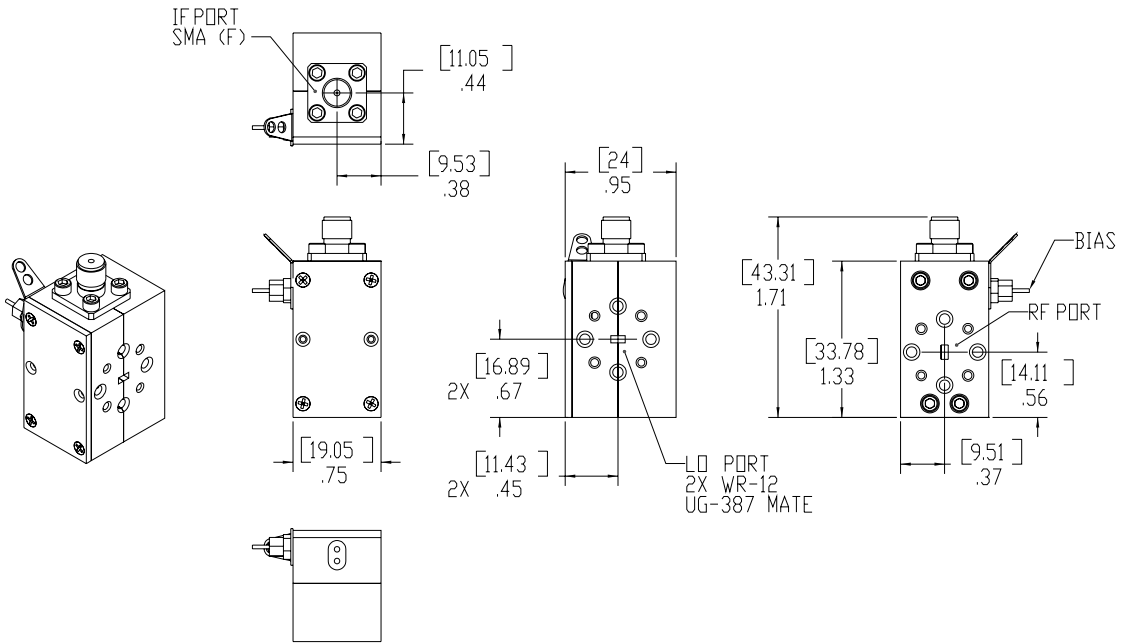

E-Band Balanced Upconverter

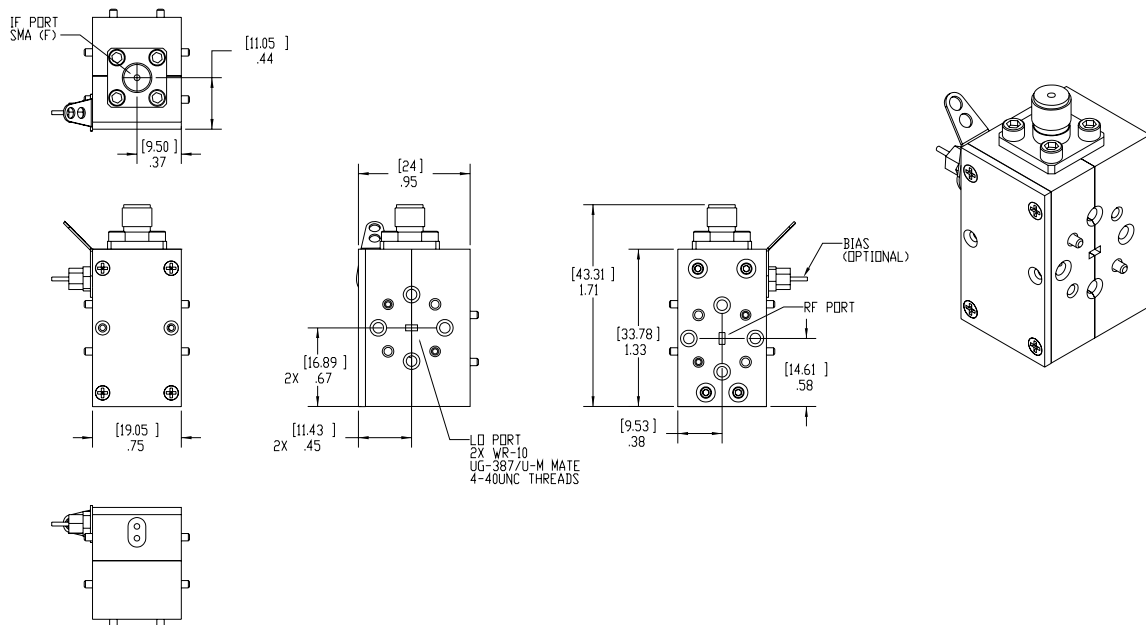

W-Band Balanced Upconverter

Typical Output Power Data for HBUC Balanced Upconverters

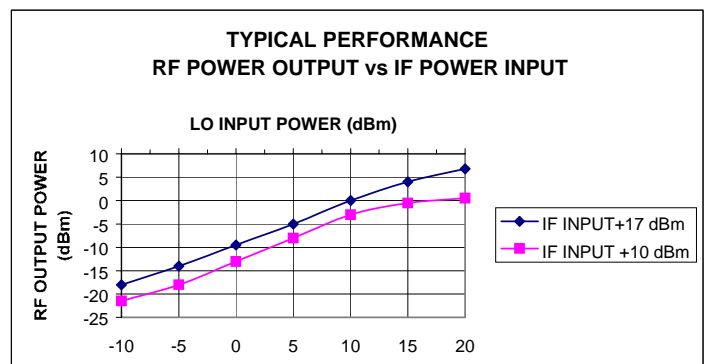
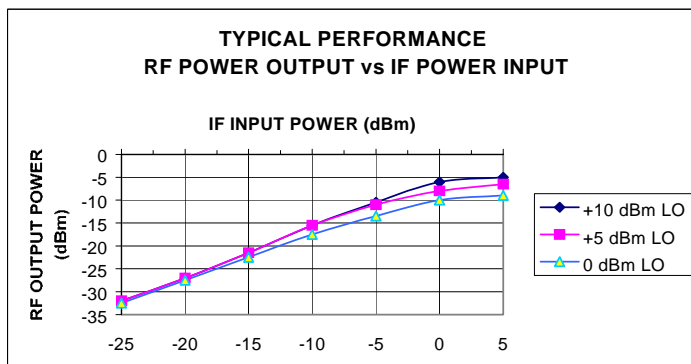
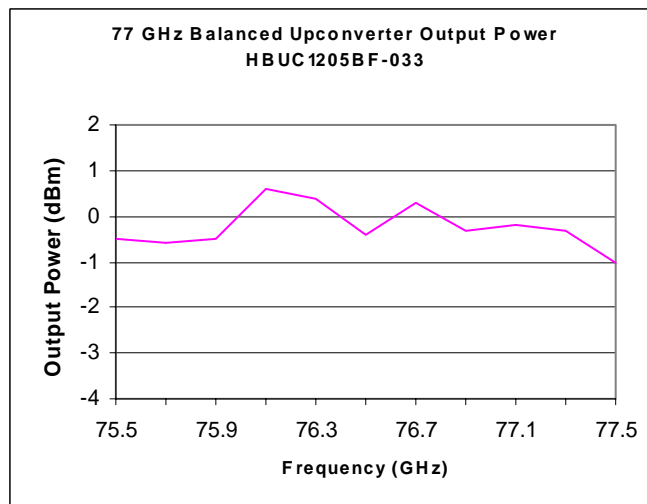
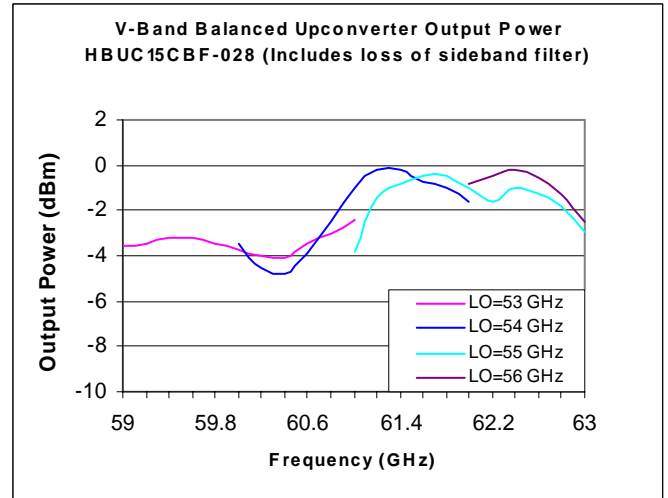
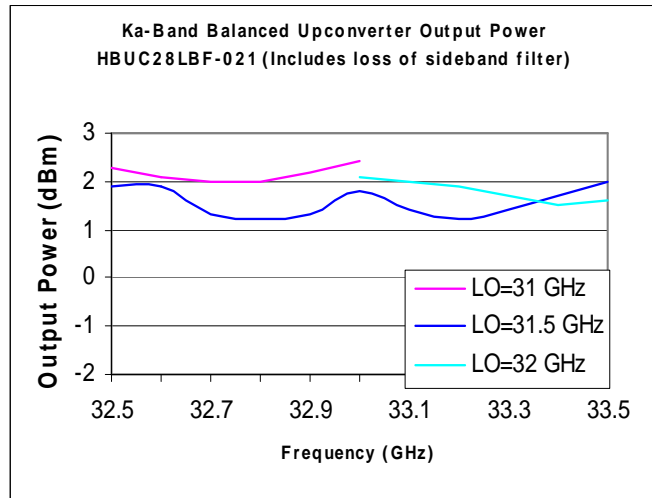



Series HBUC Balanced Upconverters

Revised October 2010

Requesting quotes

When requesting a quote for HBUC Balanced Upconverters, please specify required RF, LO and IF frequency ranges, IF and LO power, RF output power and any other required specifications. HBUC upconverters are built to order and will be optimized for the bandwidths specified by the customer. The part number guide below can also be used as a reference for requesting quotes.

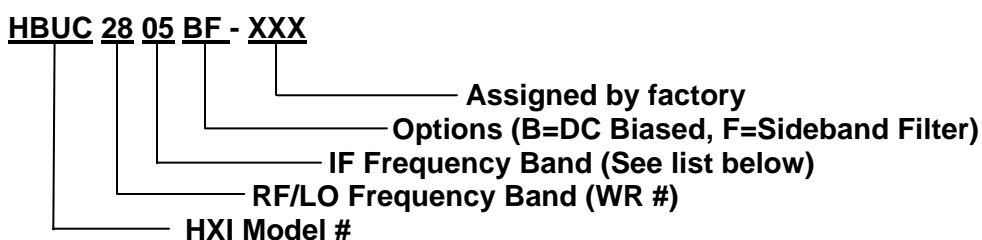

For UG-383/U Flange in B & U bands - add /383 after options

IF Frequency Band Options

01 (10-100 MHz)	02 (10-500 MHz)	03 (10-1000 MHz)	04 (10-1500 MHz)
05 (1-4 GHz)	06 (1-6 GHz)	L (1-2 GHz)	S (2-4 GHz)
C (4-8 GHz)	X (8-12.4 GHz)	Ku (12.4-18)	

Other IF bands available upon request.

Note: IF options 02 through Ku are not available for full band (RF & LO) units.